

HK-6D-U303 six-axes soldering machine motion control system

User Manual

Shenzhen HengKong Technology Co.,Ltd.

**Address: Floor 4, Building D, Phase II, Huafeng International Robotics Industrial Park,
Guxing Community, Xixiang Street, Baoan District, Shenzhen.**

Tel: 0755-27726892 Fax: 0755-23017249

Catalog

Chapter 1 Summary	1
1.1 Hardware	1
1.2 Software	2
1.3 Accessory	2
1.4 Main board base plate mounting dimensions Figure	4
1.5 Digital tube installation size schematic	4
1.6 System interface and wiring schematic	5
Chapter 2 Main interface and press key description	9
2.1 Main interface and description	9
2.2 Teach box Key Description	10
2.3 Program Selection and Alignment Key Description	13
Chapter 3 Basic method for programming description	14
3.1 Unit symbol interpretation	14
3.2 Appointment for soldering program finish	14
3.3 Run mode of soldering program	14
Chapter 4 Menu 1	16
4.1 Page 1 1. File name edit	16
4.2 Page 1 2. Create default value	16
4.3 Page 1 3. Multi record edit	17
4.4 Page 1 4. Label set	18
4.5 Page 1 5. Dispense array	18
4.6 Page 1 6. Array expand	19
4.7 Page 1 7. Call Sub	19
4.8 Page 1 8. Call file	19
4.9 Page 1 9. Program jump to	19
4.10 Page 2 1. Limited loop	20
4.11 Page 2 2. Program end	20
4.12 Page 2 3. Delay	20
4.13 Page 2 4. Pause	20
4.14 Page 2 5. Input program	20
4.15 Page 2 6. Output program	20
4.16 Page 2 7. Work counter	20
4.17 Page 2 8. Go free position	21
4.18 Page 2 9. Go home	21

4.19	Page 3	1. Clear iron	21
4.20	Page 3	2. Z-axis single move	21
4.21	Page 3	3. XY-axis move	21
4.22	Page 3	4. A-axis move	21
4.23	Page 3	5. Send tin on/off	21
Chapter 5 Menu 2			22
5.1	Page 1	1. Manual adjust set	22
5.2	Page 1	2. Manual adjust option	22
5.3	Page 1	3. Z-axis down limit	23
5.4	Page 1	4. Free coor set	23
5.5	Page 1	5. Clean iron option set	23
5.6	Page 1	6. Clean iron speed set	24
5.7	Page 1	7. Clean iron coors set	24
5.8	Page 1	8. Output when estop	24
5.9	Page 1	9. Output when init	25
5.10	Page 2	1. Debug speed set	25
5.11	Page 2	2. Work counter set	25
5.12	Page 2	3. Weld counter set	25
5.13	Page 2	4. Go home cnt set	25
5.14	Page 2	5. Middle stop/remember	25
5.15	Page 2	6 Dot para set/ Move speed para set	26
		5.15.1 Dot para set (group function on)	26
		5.15.2 Move speed para set (group function off)	26
5.16	Page 2	7 Drag para set/ Drag chang speed set	27
		5.16.1 Drag para set (group function on)	27
		5.16.2 Drag chang speed set (group function off)	27
5.17	Page 2	8. Close para set	27
5.18	Page 2	9 Show run state set/ Get product position	28
		5.18.1 Show run state set (group function on)	28
		5.18.2 Get product position (group function off)	28
5.19	Page 3	1. Start angle set	28
5.20	Page 3	2 Get product position/ Safety height set	28
		5.20.1 Get product position (group function on)	28
		5.20.2 Safety height set (group function off)	28
5.21	Page 3	3. Drag speed set	29

5.22 Page 3	4. Send&Back para set	29
5.23 Page 3	5. Shale tin set	29
5.24 Page 3	6. Return set	30
5.25 Page 3	7 Show run state set	30
Chapter 6 Menu 3	31
6.1 Page 1	1. Needle move to	31
6.2 Page 1	2. File copy option	31
6.3 Page 1	3. Convert DXF file	32
6.4 Page 1	4. File lock/unlock	32
6.5 Page 1	5. Machine lock/unlock	32
6.6 Page 1	6. File lock pass set	32
6.7 Page 1	7. Machine lock pass set	32
6.8 Page 1	8. Input name edit	33
6.9 Page 1	9. Output name edit	33
6.10 Page 2	1. Key voice on/off	33
6.11 Page 2	2. Small key lock/unlock	33
6.12 Page 2	3. File name view	33
6.13 Page 2	4. Machine information	33
6.14 Page 2	5. Program edition	33
6.15 Page 2	6. Update app	34
6.16 Page 2	7. View input	34
6.17 Page 2	8. View function key	34
6.18 Page 2	9. Run from cursor	35
6.19 Page 3	1. Run select area	35
6.20 Page 3	2. View control output	35
Chapter 7 Menu 4	36
7.1 Page 1	1-6. X, Y, Z, A, Y2 axis para set	36
7.2 Page 1	7. Solder axis para set	37
7.3 Page 1	8. Time limited pass set	38
7.4 Page 1	9. Time limited set	38
7.5 Page 2	1. Machine name edit	38
7.6 Page 2	2. Company name edit	38
7.7 Page 2	3. Start/Stop speed Set	39
7.8 Page 2	4. Acc set	39
7.9 Page 2	5. Max speed set	39

7.10	Page 2	6. Go home speed set	40
7.11	Page 2	7. Manual speed set	40
7.12	Page 2	8. Update ime	40
7.13	Page 2	9. Update power screen	40
7.14	Page 3	1. Program change mode	40
7.15	Page 3	2. Y&A-axis num set	41
7.16	Page 3	3. System para copy	41
7.18	Page 3	4. Estop mode	42
7.19	Page 3	5. Home mode of power on	42
7.20	Page 3	6. Machine type set	42
7.21	Page 3	7. Key input port set	42
7.22	Page 3	8. Output port set	43
7.23	Page 3	9. Driver wire mode	43
7.24	Page 4	1. A negative angle set	43
7.25	Page 4	2. Input port set	43
7.26	Page 4	3. Input port mode set	44
7.27	Page 4	4. Output port set	44
7.28	Page 4	5. Run mode in double Y	44
7.29	Page 4	6. Protect set	45
7.30	Page 4	7. Function configure	45
7.31	Page 5	8. Clamp port set	46
7.32	Page 4	9. Sensor check port	46
7.33	Page 5	1. Get cylinder port	47
7.34	Page 5	2. Get cylinder delay	48
7.35	Page 5	3. Get cylinder sensor	48
7.36	Page 5	4. Output configure 1	49
7.37	Page 5	5. System language	49
7.38	Page 5	6. Init system para	49
Chapter 8 Default menu			50
Chapter 9 Menu show and hide			51

Chapter 1 Summary

The HK-6D-U303 automatic soldering motion control system has the ability to control 6 motor axes at the same time, and can be used for a variety of mechanical structures such as gantry type, single platform type and double working table, etc. The addition of hidden menu function also makes the system achieve the effect of both professional and easy to use. The teach box of the machine adopt the 5 inch true-color LCD screen to make the operation menu and boot screen more abundant. To make the transmission speed faster and signal Anti-Interference, and can copy the dispensing processing files or system configuration files to each other during the use of multiple devices. Mass production. The system adopts ARM+DSP control program, with a strong computing power, short refresh time, excellent acceleration and deceleration performance in motion control. Motion control Main board with 32M storage space, can store 150 processing files, each file can store 1500 processing programming points, can support the work in the absence of teach box connection, processing files can be digital tube plus key way to select.

1.1 Hardware

1. Motor axis output: 6 axis output.
2. Acceleration and deceleration characteristics: acceleration and deceleration acceleration are set independently.
3. Pulse output frequency: up to 1 MHz pulse output.
4. Programmable inputs and outputs: 24 programmable inputs and 16 programmable outputs ,all used optical isolation and each output current up to 500mA.
5. Supporting 3 bits digital number tube interface, can change and switch 150 soldering files range 0-149 quickly.
6. Using the small key to adjust the iron head, in the absence of a teach box can also facilitate the realization of the error due to changing the iron head correction.
7. Read/Write in U Disk: FAT32 file system, no longer than 2G capacity U disk cannot be formatted to limit the FAT format.
8. Storage space: main board 32Mb, can store 150 soldering processing files, each with 1500 program points; teach box 4MB, which can store system parameters and processing files, especially useful for copying dispensing files to each other in multiple machines.
9. Teach box screen: Use 480 X 272 pixels, 16 million true color 5-inch LCD screen.
10. Operating voltage: DC 24V.
11. Working environment: degree 0°C--45°C, humidity 40%--80%.
12. Storage environment: degree -40°C--60°C, humidity 0%--95%.

1.2 Software

1. Programming point of the editor can be 20 times the "undo" "redo", to prevent misuse effectively.
2. Machining parameter setting in the form of programming points, which enables different machining parameters to be set for different areas in the same machining process.
3. Support a total of 50 groups of processing parameters from 0-49, to cope with different processing needs of the same product, fast setting, convenient and efficient.
4. (a) In the home return action, each axis returns to the home position and then the five axes X, Y, Z, A and Y2 are captured at the same time.
5. With Quanpin IME to input Chinese.

1.3 Accessory

1. Main board (HK-6D-U303)

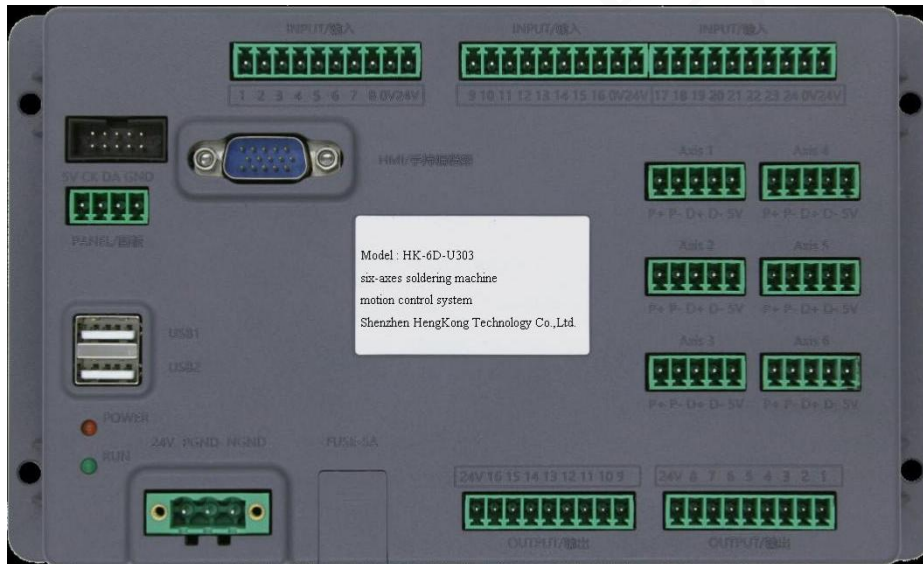

2. Teach box (242mm * 142mm * 26mm)



3. Program group selection and manual pin-to-pin keypad (107mm * 40mm), circuit board (70mm * 40mm)
4. Connection cable (length can be developed)

Name	Quantity	Unit	Length (m)
DB15 extension cable	1	Article	1.5
USB extension cable	1	Article	0.75
DB15 extension cable (elbow)	1	Article	0.75



DB15 extension
cable

USB extension
cable

DB15 extension cable
(elbow)

1.4 Main board base plate mounting dimensions Figure

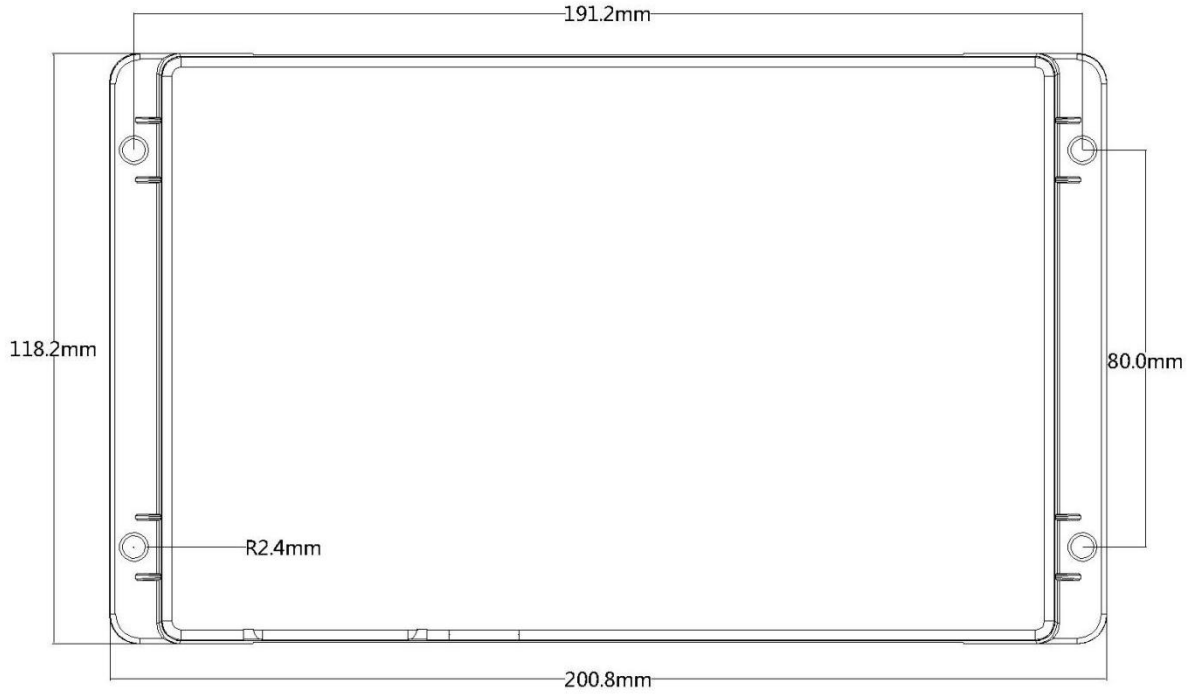

HK-6D-U303 dimensional drawing

1.5 Digital tube installation size schematic

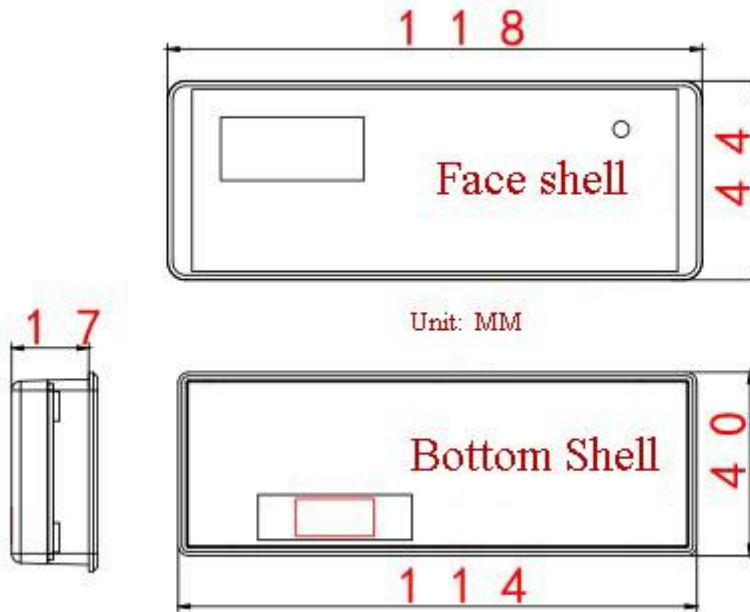

1.6 System interface and wiring schematic

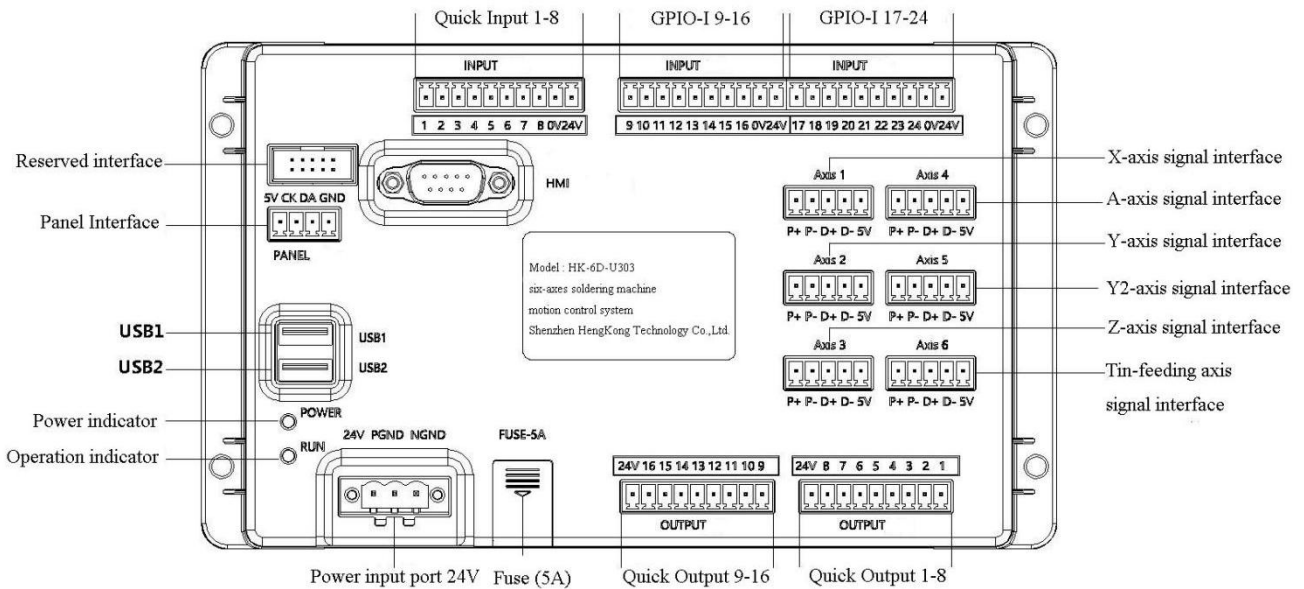

HK-6D-U303 interface schematic

Special interface definition and description.

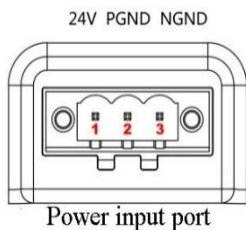

PWRIN Power Input Port Pin Definition and Description			
Serial number	Name	Function	Wiring Description
1	24V	24V power input	Connect 24V switching power supply VCC (DC V+)
2	PGND	0V	Connect 24V switching power supply 0V (DC V-)
3	NGND	Ground Line	Connect 24V switching power supply FG (\perp)

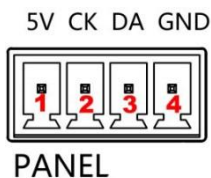

PANEL Panel Pin Definitions and Descriptions			
Serial number	Name	Function	Wiring Description
1	5V	5V Power supply to pin panel	Connect program set and pair of pin panel power VCC/5V
2	CK	Clock signals	Connecting program set and pair of pin panel clock cables CK
3	DA	Data Signal	Connecting program set and pair of pin panel data cable DA
4	GND	Counterpane ground	Connect program group and pair of pin panel ground 0V/GND

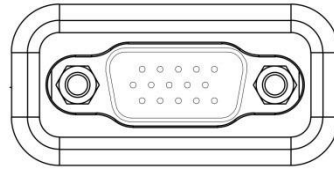

HMI

Teach box interface direct connection DB15 extension cable

Input port definition and description:

Input / input port pin definition and function description			
Serial number	Name	Function	Wiring Description
1	Input 1	X-axis home signal	X-axis home sensor signal foot OUT (black line)
2	Input 2	Y-axis home signal	Y-axis home sensor signal foot OUT (black line)
3	Input 3	Z-axis home signal	Z-axis home sensor signal foot OUT (black line)
4	Input 4	A-axis home signal	A-axis home sensor signal pin OUT (black line)
5	Input 5	2Y-axis home signal	2Y-axis home sensor signal pin OUT (black line)
6-8	Inputs 6-8	Programmable fast input port	Can be connected to buttons, electric batch blocking signals, pair of pin signals, etc. (support capture)
9-24	Inputs 9-24	Programmable common input	Input signals such as buttons and sensors can be connected (capture is not supported)

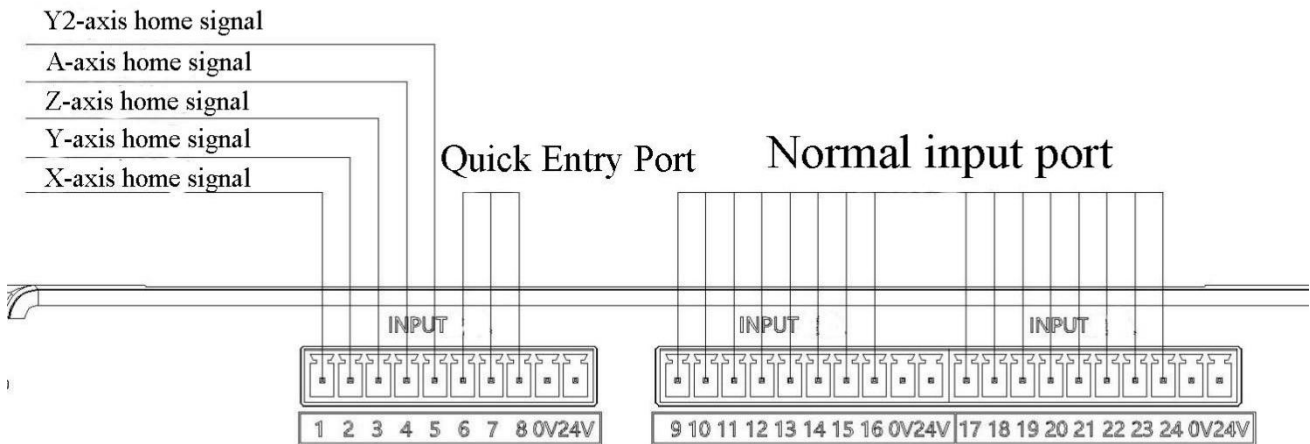

Input port typical wiring: relay transit method:

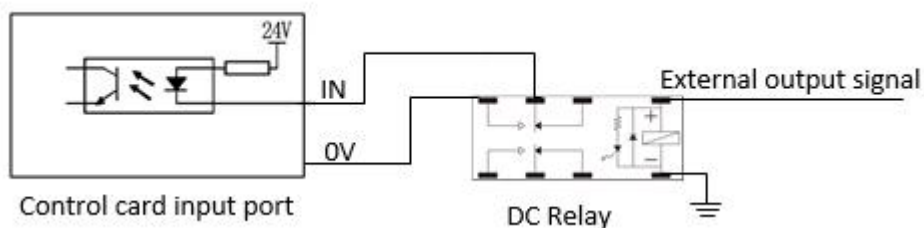

Output port definition and description:

Output / Output port pin definition and function description			
Serial number	Name	Function	Wiring Description
1-7	Outputs 1-7	Quick Output Port	Fast output for control of peripheral devices
8	Brake signal	Brake control signal	Default is brake control signal, can be configured as normal output port
9-16	Outputs 9-16	Quick Output Port	Fast output for control of peripheral devices

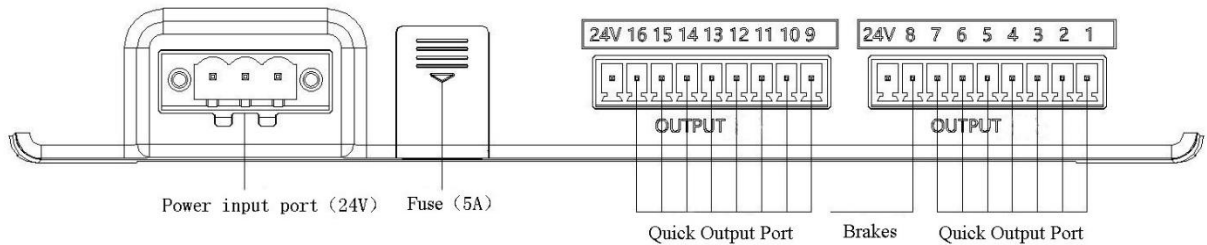
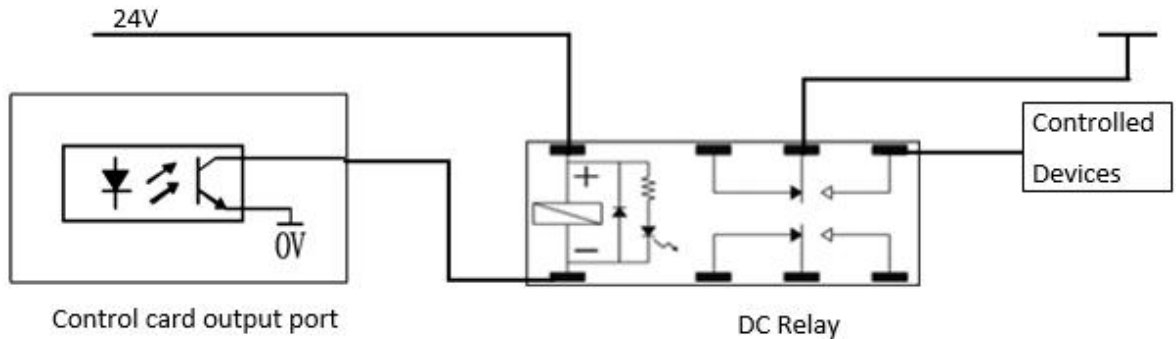
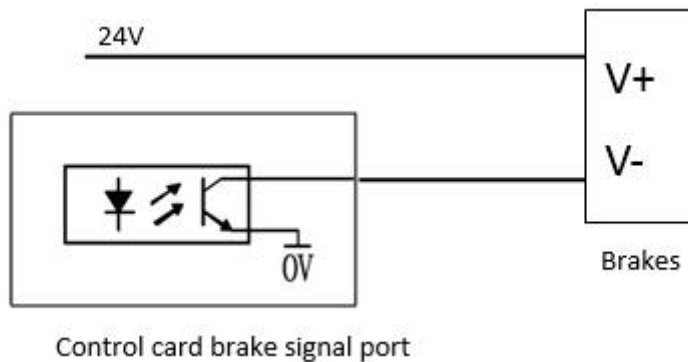
Typical wiring of output port: relay transit method:

Brake wiring diagram:

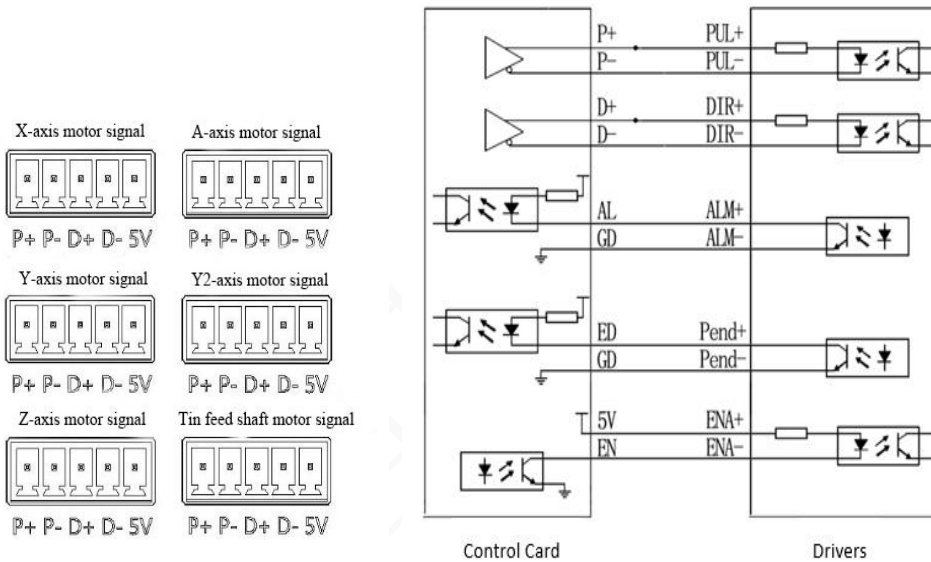
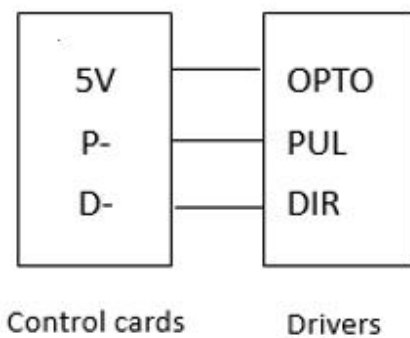
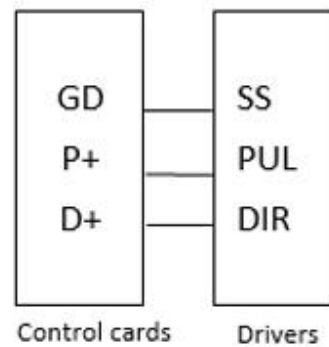
Motor signal pin definition and description:

Motor signal pin definition and function description			
Serial number	Name	Function	Wiring Description
1	P+	Pulse signal +	Motor pulse positive signal, differential signal type (5V voltage domain)
2	P-	Pulse signal-	Motor pulse negative signal, differential signal type (5V voltage domain)
3	D+	Directional signal +	Motor direction positive signal, differential signal type (5V voltage domain)
4	D-	Directional signals-	Motor direction negative signal, differential signal type (5V voltage domain)
5	5V	5V DC power supply	5V DC power supply











Differential mode wiring diagram:

Common Anode Wiring Diagram

Common Cathode Wiring Diagram

Chapter 2 Main interface and press key description

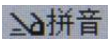
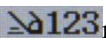
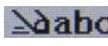
2.1 Main interface and description









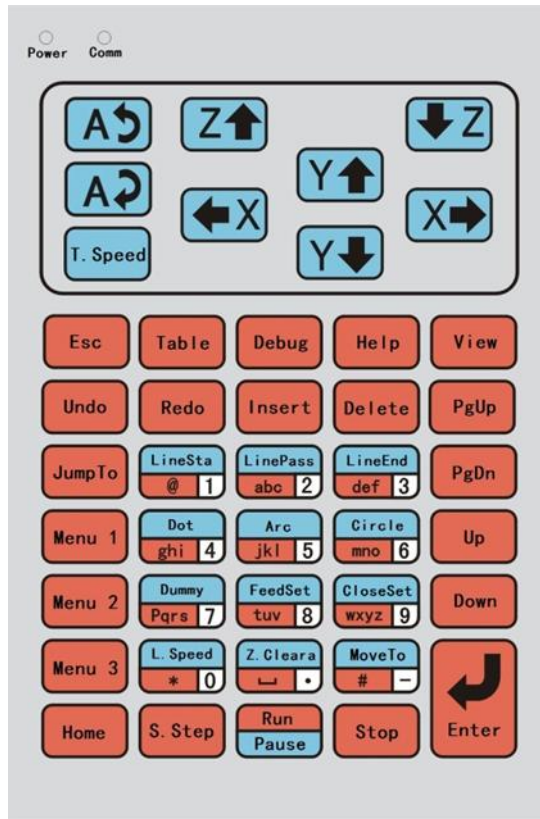

1. Main interface description of content distribution.

























2. **000:程序000** Soldering file No. And File name, “005” is No., “Prog005” is file name.
3. **Modify :2021-05-06 20:07:44** Latest modified time of the soldering file.
4.  Icon of open soldering file, can use “Table” key move the cursor to this icon.
5.  “undo”“redo”state indication icon, up to 30 times to “undo”, “redo”, but can’t use when icon is gray.
6.  Means the soldering file is edited, need “debug” operation, when already debugged, the icon becomes gray.
7.  File is not locked,  file is locked,  machine is locked.
8. **Speed:M** Move speed by manual, part of “fast, middle, slow”, press the "speed" key to switch.
9. **Cnt :0/0** Workpiece counter, in front of the value is the count value of the workpiece, behind the value set the number of workpieces to be processed. If the work count reach the number of set to be processed, it will prompt that the workpiece counter is full, and if there is no work piece number limit, set the limit number as ‘0’.
10.  Insert U Disk,  No U Disk.
11.  Pinyin input,  number input,  lower-case letter input,  capital letter input, Press “#” can change the IME when in the character input state.

2.2 Teach box Key Description











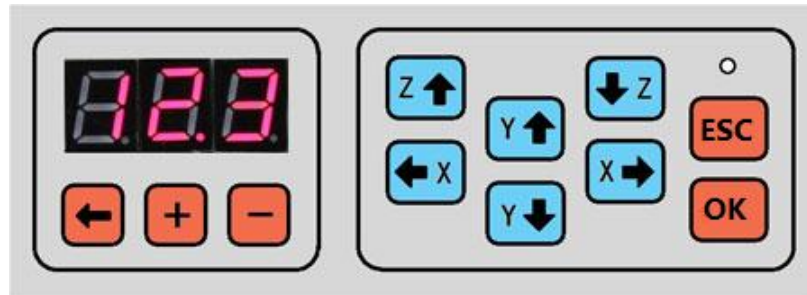



1.  Z axis up by manual
2.  Z axis down by manual
3.  Y axis front by manual
4.  Y axis back by manual
5.  X axis left by manual
6.  X axis right by manual
7.  The fourth axis named A axis counter clockwise rotation by manual
8.  The fourth axis named A axis clockwise rotation by manual
9.  Switch manual speed “slow, middle, fast”
10.  Operation of exiting the menu or canceling the input dialog
11.  Cursor switch between “soldering programming point” area and “short menu bar” area, or transform plane when previewing.

12.  Analysis of the current soldering file whether its programmed point accord with the soldering programming rules, if yes, then the icon  will become gray.
13.  Press this key can pop up some help information of the current page, press any key to exit
14.  Press this button to preview the current processing program file XY plane of the solder path graphics, press the  key to exit the interface; press  Access to offset operations, coordinate offsets and taught offsets, coordinate offsets and taught offsets, as described in Menu 1 "Edit multiple programming points" function.
15.   Undo and redo to the edition of programming points, up to 30 times, for preventing misuse effectively.
16.  In front of the cursor point of the selected insert a blank soldering program point.
17.  Delete the programming point of selected in main page, or in the menu state use for "delete" key.
18.  Jump to the special programming point address by manual input.
19.  Into Menu 1, for the soldering point of action, displaying as black.
20.  Into Menu 2, for soldering point of parameters setting, displaying as red.
21.  Into Menu3, for device of parameters setting and some application operation
22.  Perform to home.
23.  Perform step soldering test.
24.  Soldering working run or pause.
25.  Soldering working stop.
26.  Cursor up a page in main page state, or up a page in menu state.
27.  Cursor down a page in main page state, or down a page in menu state.
28.  Cursor up a line in main page state, or up a line in menu state, or up a line in input dialog.
29.  Cursor down a line in main page state, or down a line in menu state, or down a line in input dialog.

30.  Start point of drag soldering program in main page, or input '1', characters in input dialog.
31.  Middle point of drag soldering program in main page, or input '2', 'abc' in input dialog.
32.  Finish point of drag soldering program in main page, or input '3', 'def' in input dialog.
33.  Dot welding program in main page, or input '4', 'ghi' in input dialog.
34.  Drag the arc welding program in main page, or input '5', 'jkl' in input dialog.
35.  Drag soldering program in main page, or input '6', 'mno' in input dialog.
36.  Soldering dump point(dump point is just like the dot welding, only move to the point coordinate, but no more action, mainly used to other expect soldering, such as clear iron head, etc) program in main page, or input '7', 'pqrs' in input dialog.
37.  Input '8'or 'tuv' in input dialog.
38.  Input '9'or 'wxyz' in input dialog.
39.  Set parameters of drag soldering speed program in main page, or input '0 ' in input dialog.
40.  Set Z height parameters in main page, or input space character or decimal point in input dialog.
41.  Move the iron head to the programming point of cursor selected in main page when there is coordinate occurred, or switch IME or input negative value symbol in input dialog.
42.  Change Y axis between Y1 and Y2 then display when in double Y mode.
43.  Into menu 4, for bottom layer parameters of the device, suggested not open to users..
44.  Enter menu 5, which is the system default parameter setting, and set the initial value of menu 1 "Generate default parameters".
45.  Access to menu 6, which is the interface for entering the "Show and hide menu" settings and is recommended to be closed to users.
46.  Screenshot function to capture the whole screen.

2.3 Program Selection and Alignment Key Description



1.  The current file selected is soldering file 123.
2.  Move the decimal point bit of the current soldering file No., there is '+', '-' operation follow with the decimal point bit.
3.  Plus 1 on the bit of decimal point in the soldering File No.
4.  Minus 1 on the bit of decimal point in the soldering File No.
5.  Z axis move up by manual when adjusting base point.
6.  Z axis move down by manual when adjusting base point.
7.  Y axis move front by manual when adjusting base point.
8.  Y axis move back by manual when adjusting base point.
9.  X axis move left by manual when adjusting base point.
10.  X axis move right by manual when adjusting base point.
11.  Enter or confirm the adjustment operation for base point, when enter the adjustment to the base point position, LED on the back of the film began flashing, press manual key then press confirm key to finish the operation.
12.  Cancel the adjustment operation.

Chapter 3 Basic method for programming description

3.1 Unit symbol interpretation

1. Length unit (mm) = (millimeter)
2. Time unit (s) = (second)
3. Speed unit (mm/s) = (millimeter per second)
4. Acceleration unit (mm/(s*s)) = (speed of increment of millimeter per second for one second)

3.2 Appointment for soldering program finish

To improve the readability of the soldering program, programming points can be kept a 'Non program' line between the lines, if there are two consecutive lines of 'Non program', then means here is the end of the program or subroutine return, its useful is the same as 'Program end or return'.

3.3 Run mode of soldering program

The running of soldering program is according to the sequence from address 0001 begin, and down to execute action or parameter setting of each program point until the program end or press 'stop', 'emergency' key. Among those program points expect the point of dot welding, drag welding, also have the order such call,array, jump, delay, pause, etc.

As using program point method in processing parameters setting, so as long as insert the parameters setting program point to the welding processing, we can achieve use different soldering parameters in different soldering area in one processing file.

For example, the following procedure:

```

000:程序000                                     Modify :2021-05-06 20:12:46
[Icons] | Mode:Work | Speed:M | Cnt :0/0 [Icon]
0001 Drag Speed:100.000(mm/s) Send Tin Speed:50.000(mm/s)
0002 Line Start X:31.273 Y:29.437 Z:19.703
0003 Line End X:56.786 Y:52.959 Z:21.450
0004 Drag Speed:150.000(mm/s) Send Tin Speed:100.000(mm/s)
0005 Line Start X:35.490 Y:37.554 Z:19.305
0006 Line End X:94.892 Y:102.529 Z:19.305
0007 Drag Speed:200.000(mm/s) Send Tin Speed:150.000(mm/s)
0008 Line Start X:94.892 Y:102.529 Z:19.305
0009 Line End X:41.689 Y:35.035 Z:19.305
0010 No Record
X:41.689      Y:35.035      Z:19.305      | 20:13:06
  
```

In the program, the line segment consisting of 0002-0003 performs drag soldering at a speed of 100 mm/s, the

line segment consisting of 0005-0006 performs drag soldering at a speed of 150 mm/s, and the line segment consisting of 0008-0009 performs drag soldering at a speed of 200 mm/s. And the speed of the soldering drag is also determined by the parameters set before the corresponding program.

恒控科技

Chapter 4 Menu 1

Menu 1 is for performing action programming and common file operations. The programming points generated by Menu 1 are usually operation classes, which are displayed in black in the main interface. Menu 1 includes the following.

Menu1	PG 1/3	Menu1	PG 2/3	Menu1	PG 3/3
1.File Name Edit		1.Limited Loop		1.Clean Iron	
2.Create Default Value		2.Program End		2.Z-Axis Single Move	
3.Multi Record Edit		3.Delay		3.XY-Axis Move	
4.Label Set		4.Pause		4.Send Tin On/Off	
5.Dispense Array		5.Input Program			
6.Array Expand		6.Output Program			
7.Call Sub		7.Work Counter			
8.Call File		8.Go Free Position			
9.Program Jump To		9.Go Home			

4.1 Page 1 1. File name edit

Name the current processing file, support full spelling, upper and lower case English and numeric input, press



the key to switch the input method, and show the current input method type in the upper right corner of the display.

4.2 Page 1 2. Create default value

Default parameters can be generated in front of the file:

1. Air travel speed: X, Y, Z axis air travel speed.
2. contact welding joint action: vertical height, plane distance, approach speed.
3. A-axis movement: rotation and then XY-axis movement, rotation and XY-axis movement at the same time, XY-axis movement to the top first and then rotation.
4. physical angle: the physical angle at the start of the A-axis.
5. Safety height & lifting height setting: safety height, lifting height, working cylinder down or not, cylinder down delay, working cylinder lifting or not, cylinder lifting delay time.
6. drag welding speed and drag welding out of tin speed.
7. Tin feeding and tin rejection parameters setting: three pages, the first page to the third page are the first, second and third tin feeding length, tin feeding speed, tin rejection length, tin rejection speed and heating time. The first page to the third page are the first, second and third feeding length, feeding speed, retreating length, retreating speed, heating time, and the third page also contains the early stop feeding length.
8. Jitter function settings: jitter function enabled or not, jitter direction, jitter times, jitter distance, jitter speed, jitter process out of the tin or not, dithering out of tin speed.

9. return: original way, direct, spot welding or drag welding when the end, according to the contact action original way back or direct return.

There is an important function "Group" in the soldering machine, the number of items of the default parameters generated when this function is on and off is different.

The initial value of the default parameters can be set by "Stop + Menu 2" to enter Menu 5. The menu can quickly generate all common soldering parameters. Each welding process parameter can also be generated individually in menu 2, and can be quickly modified one by one after being selected in the main interface.

Group function off:

```

0001 Move(mm/s) X:400 Y:400 Z:100
0002 Close Para Set
0003 Start Angle(deg):270.000
0004 Safety & Up Height Set
0005 Drag Speed:10.000(mm/s) Send Tin Speed:10.000(mm/s)
0006 Solder Send&Back Para Set
0007 Shake Tin Para Set
0008 No Record
0009 No Record
0010 No Record
  
```

Group function opens:

```

0001 Move(mm/s) X:400 Y:400 Z:100
0002 Close Para Set
0003 Start Angle(deg):270.000
0004 No Record
0005 No Record
0006 No Record
0007 No Record
0008 No Record
0009 No Record
0010 No Record
  
```

4.3 Page 1 3. Multi record edit

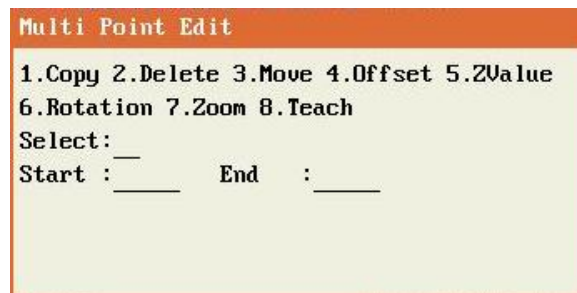

1. copy

Copies the programmed points in the edit range to the specified programmed point address. And you can offset the first coordinate point in the edit range to the coordinate point that you move to manually, and use this as a base to offset all coordinates in the edit range.

2. Delete

Delete the programmed points in the edit range.

3. Move

Moves the programmed points within the editing range to the specified programmed point address. This function is mainly used to adjust the processing order of each weld point.

4. Offset

Offset the coordinate values of the solder joints within the editing range, the offset value can be positive or negative.

5. ZValue

Set the Z-axis coordinate value of the weld point within the editing range to a uniform value.

6. Rotation

Rotate the weld trajectory or weld point position within the editing range. This function can be used to correct the weld trajectory and weld point position without reprogramming in case of, for example, fixture deformation.

7. Zoom

Enlarges or reduces the weld path or weld point position graphics within the editing range, mainly for correcting the scale deviation between the coordinates generated by the DXF file and the actual coordinates of the machine when the DXF file is converted into a machining file.

8. Teach

Offset the first coordinate point of the edit range to the coordinate position to which it was manually moved, and use this as a reference for the overall offset of all coordinate points in the edit range.

9. Change Y-axis

Set the Y-axis coordinates of the programmed points in the editing range to Y1 or Y2 axis, which exists only in the double Y mode.

4.4 Page 1 4. Label set

Markers can be used for calls to arrays, loops, calling subroutines, program jumps, and generic input programming, etc. They can also be used to comment programming to improve readability.

4.5 Page 1 5. Dispense array

The array function can be used if the workpieces on the machining fixture tray are regularly arranged horizontally and vertically, and the spacing is the same in the horizontal and vertical directions respectively, so that the complete machining file of one workpiece can be edited, and then the array function can be used to realize the machining of the whole tray of workpieces, which simplifies the programming and improves the programming efficiency. Array programming is available in the following two ways.

Array

- 1.Array As Input Offset**
- 2.Array As Teach Offset**

The first array method can be used when the plane of the fixture where the workpiece is placed is consistent with the XY plane, and the lateral and vertical directions are parallel to the X and Y axes, and the second array method can also be used. The second array method is used when the fixture plane of the workpiece is not consistent with the XY plane, or when the lateral and vertical directions are not parallel to the X and Y axes.

Array	Array
Array :1.Hori 2.Vert 3.'Z' Path : __	Array :1.Hori 2.Vert 3.'Z' Path : __
Hori Num : _____	Hori Num : _____
Vert Num : _____	Vert Num : _____
Offset-X(mm): _____	HoriCoor: _____
Offset-Y(mm): _____	VertCoor: _____
Call :1.Addr 2.Label Select: __	Call :1.Addr 2.Label Select: __
Addr : _____	Addr : _____

4.6 Page 1 6. Array expand

The array programming point is selected by the cursor in the main interface, and the array expansion operation can generate programming points with the same effect as the array, and this function can be used to modify the screw hole position of each workpiece individually when the jig plate is not very regular.

4.7 Page 1 7. Call Sub

If multiple workpieces with the same orientation but irregular position are placed on the machining fixture tray, it is only necessary to program the machining of one workpiece and then call the subroutine at the first screw hole position of each workpiece, the calling subroutine can be the address of the subroutine or the label of the subroutine.

4.8 Page 1 8. Call file

Calling a file is similar to calling a subroutine in use and function, turning the called subroutine into a call to a machining file number and the machining programming point in the subroutine into the machining programming point of the called file.

4.9 Page 1 9. Program jump to

When the program is executed at this point, the program jumps to the specified address or marker and is generally used for loops, etc. For example, if you add a program to jump to address 0001 at the end of the program, the program will keep working in a loop.

4.10 Page 2 1. Limited loop

The function of finite number of loops is similar to that of "program jump", except that "program jump" has an unlimited number of times, while finite number of loops has a limited number of jumps, and the jump of finite number of loops can only jump to the front of its own programming point to be effective, while program jump can jump to any address.

4.11 Page 2 2. Program end

When the programmed point is executed in the subroutine, the subroutine returns, and when the programmed point is not executed in the subroutine, the machining program ends, which is the same as "unprogrammed blank programmed point" with two or more consecutive lines. The machining program is considered to be finished when there are two or more consecutive "unprogrammed blank programming points".

4.12 Page 2 3. Delay

If the program execution reaches the delayed programming point, the machining is paused and the set time is delayed before continuing to the next machining programming point.

4.13 Page 2 4. Pause

When the program reaches the pause programming point, machining is paused until the "Run" key is pressed and then the program continues to the next programming point. The "run key loop" can be implemented by adding a pause at the end of programming point Y1, a pause at the end of programming point Y2, and finally a jump instruction.

4.14 Page 2 5. Input program

The function of input signal programming is that when the program executes to the programmed point, if the input status of the specified input signal matches the programmed value, the program jumps to the specified address or marker, if not, the program continues to execute. This function can be used to work with other devices or as a pause button input, etc. (Signal definition: if there is a signal, the signal is defined as 1, if there is no input signal, the signal is defined as 0).

4.15 Page 2 6. Output program

When the program is executed to the output signal programming point, the output signal specified by the programming point will output the corresponding setting value, 1 is DC-24V output and 0 is DC-0V output. When debugging the machine, you can test the corresponding output port.

4.16 Page 2 7. Work counter

When the programmed point is reached, the workpiece counter is increased by the corresponding set value and

then the count value is compared to see if the limit value is exceeded, and stopped if it is. This function is mainly used for counting parts for cyclic machining.

4.17 Page 2 8. Go free position

When the programmed point is reached, the X, Y and Z axes return to the coordinates of the idle dwell point set in Menu 2.

4.18 Page 2 9. Go home

Executes the home position action.

4.19 Page 3 1. Clear iron

Perform cleaning action of soldering iron head.

4.20 Page 3 2. Z-axis single move

The program is executed to this programming point, and the Z-axis moves to the specified position individually.

4.21 Page 3 3. XY-axis move

When the program is executed to this programming point, the XY axis moves to the specified position.

4.22 Page 3 4. A-axis move

When the program is executed to this programming point, the A-axis moves to the specified angle alone.

4.23 Page 3 5. Send tin on/off

When the program is executed at this programming point, the control turns the tin feed signal on or off.

Chapter 5 Menu 2

Menu 2 is to be the programming point set for the soldering parameters, and the programming point generated by Menu 2 is displayed in dark red. Menu 2 includes the following: When the grouping function is off (set in Menu IV - page 4 - 4 Function Settings).

Menu2	PG 1/3	Menu2	PG 2/3	Menu2	PG 3/3
1.Manual Adjust Set		1.Debug Speed Set		1.Start Angle Set	
2.Manual Adjust Option		2.Work Counter Set		2.Safety Height Set	
3.Z-Axis Down Limit		3.Weld Counter Set		3.Drag Speed Set	
4.Free Coor Set		4.Go Home Cnt Set		4.Send&Back Para Set	
5.Clean Iron Option Set		5.Middle Stop/Remember		5.Shake Tin Set	
6.Clean Iron Speed Set		6.Move Speed Para Set		6.Return Set	
7.Clean Iron Coors Set		7.Drag Change Speed Set		7.Show Run State Set	
8.Output When Estop		8.Close Para Set			
9.Output When Init		9.Get Product Position			

When the group function is on (set in Menu IV - page 4 - 4 Function Settings).

Menu2	PG 1/3	Menu2	PG 2/3	Menu2	PG 3/3
1.Manual Adjust Set		1.Debug Speed Set		1.Start Angle Set	
2.Manual Adjust Option		2.Work Counter Set		2.Get Product Position	
3.Z-Axis Down Limit		3.Weld Counter Set			
4.Free Coor Set		4.Go Home Cnt Set			
5.Clean Iron Option Set		5.Middle Stop/Remember			
6.Clean Iron Speed Set		6.Dot Para Set			
7.Clean Iron Coors Set		7.Drag Para Set			
8.Output When Estop		8.Drag Change Speed Set			
9.Output When Init		9.Show Run State Set			

5.1 Page 1 1. Manual adjust set

Adjustment base point, when there is some processing offset caused by the offset of changing iron head, we can use the adjustment base point to correct it. There are two ways to set the adjustment point, one is take the first soldering point coordinate as the adjustment base point, the other is set the coordinate by manual, if choose the second one, move the iron head to the specified position, then press confirm.

5.2 Page 1 2. Manual adjust option

When into the calibration menu , the iron head move to the up 3mm than adjustment point automatically (Prevent collision), then move the iron head to the specified coordinate to calibrate by manual, pressing confirm to finish this calibration operation. Then all the soldering processing point will compensate the deviation from the offset of iron head to ensure machining accuracy unchanged.

This function can also use the special calibration on the keyboard to operate while no teaching box available,

as long as the machine in an idle state, we can press “confirm” key into the calibration operation, at the same time the keyboard mask on the LED will flash, then move the iron head to the specified coordinate by manual, press “confirm” again to complete the calibration of the operation, then the LED will extinguish and exit.

In dual Y-axis mode, the Y-axis is selected first, and then the alignment point is corrected.

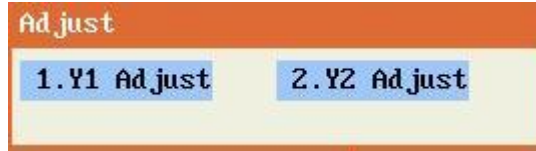

5.3 Page 1 3. Z-axis down limit

Set this value to limit Z axis down to prevent the number of collision for work piece or the tool by manual, this setting is independent of each processing program file.

5.4 Page 1 4. Free coor set

Free stop point means the position of stop when soldering processing is finished, can set as below:

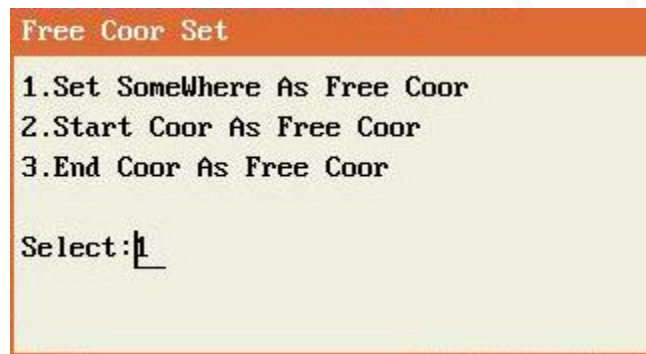

The soldering processing general can choose 2 or 3 work efficiency will be higher, but it need to choose 1 when iron head have to move away to change the product.

5.5 Page 1 5. Clean iron option set

As following picture, the interval period of automatic cleaning tip can be the number of soldering dots, or the number of products, we advise to choose the number of product if there is not too much soldering dots. The length of send tin is the amount of tin after clean out, the length of back tin is the back length after send tin, we also use these parameters when soldering, for it will automatically compensate for the length of the send tin, setting the length of the tin is no need to add the back length.

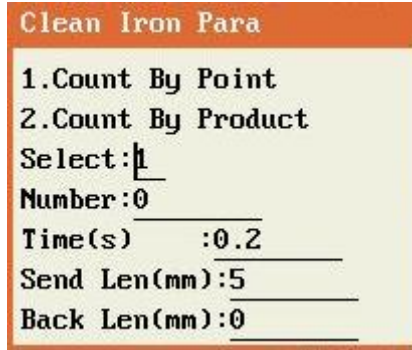

5.6 Page 1 6. Clean iron speed set

Set the settings when the soldering iron head cleaning action, including the cleaning action is carried out when the speed of tin feeding and retreat speed.



5.7 Page 1 7. Clean iron coors set

Move the iron head to the cleaning position and press the "OK" button.

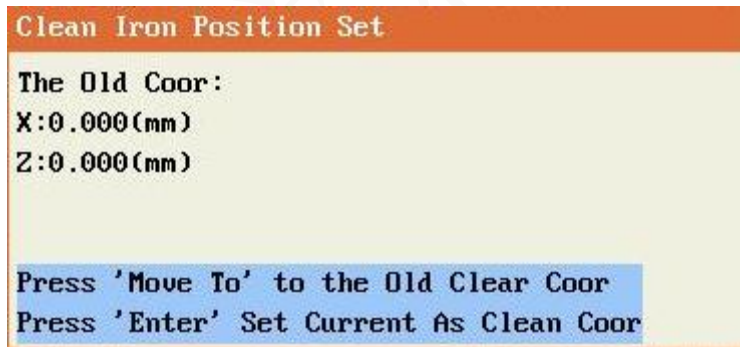

5.8 Page 1 8. Output when estop

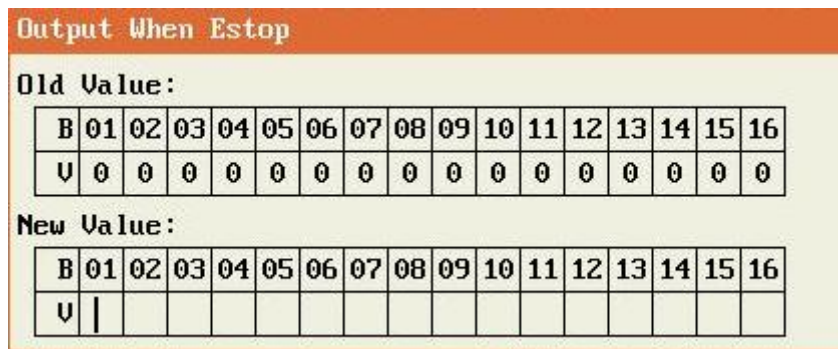

The output signal of universal output in case of emergency stop equipment, "1" is output 24V, "0" is output 0V.

5.9 Page 1 9. Output when init

Output When Init																
Old Value :																
B	01	02	03	04	05	06	07	08	09	10	11	12	13	14	15	16
V	0	0	0	0	0	0	0	0	0	0	0	0	0	0	0	0
New Value :																
B	01	02	03	04	05	06	07	08	09	10	11	12	13	14	15	16
V																

Set the output signal of universal output after power on and return to home position, "1" is output 24V, "0" is output 0V.

5.10 Page 2 1. Debug speed set

The speed set is the speed of the axis movement in "uniform" operation mode.

5.11 Page 2 2. Work counter set

We can set the count value and limit count value in the work piece counter, as running, the count value will add the set number when execute to the programming point, if the count value larger than the count limit value, prompt that count overflow, and stop processing, until set the count again. If not use the work piece count limit, please set the count limit value as 0.

5.12 Page 2 3. Weld counter set

In the welding product process, if the number of processing reach to the number ever been set, go back to the origin, then continue. If in the loop mode, then continue.

Weld Counter Set	
Cnt Value	:4
Limited	:0
No Limit,Set Limited As '0'	

5.13 Page 2 4. Go home cnt set

The number of times the product is processed is set according to the production task, and the machine performs a return-to-home action after processing to the set quantity to avoid the offset caused by lost steps.

5.14 Page 2 5. Middle stop/remember

When the stop button is pressed in the middle of processing.

Selecting Continue: the next time the operation is started, the soldering process continues from the position of the last stopped soldering process coordinates.

Select Clear: The next time you start a run, start soldering from the first solder processing coordinate position.

5.15 Page 2 6 Dot para set/ Move speed para set

5.15.1 Dot para set (group function on)

Select the group first, and then go to the specific parameter setting page:

Dot Para Set	
Group(0-49): <input style="width: 50px;" type="text"/>	
Group 01 Dot Para PG 1/4	Group 01 Dot Para PG 2/4
First Send Speed(mm/s): <input style="width: 50px;" type="text" value="10"/>	Second Send Speed(mm/s): <input style="width: 50px;" type="text" value="10"/>
First Send Length(mm): <input style="width: 50px;" type="text" value="0.000"/>	Second Send Length(mm): <input style="width: 50px;" type="text" value="0.000"/>
First Back Speed(mm/s): <input style="width: 50px;" type="text" value="50.000"/>	Second Back Speed(mm/s): <input style="width: 50px;" type="text" value="0.000"/>
First Back Length(mm): <input style="width: 50px;" type="text" value="0.000"/>	Second Back Length(mm): <input style="width: 50px;" type="text" value="0.000"/>
First Heat Time(s): <input style="width: 50px;" type="text" value="0.000"/>	Second Heat Time(s): <input style="width: 50px;" type="text" value="0.000"/>
Cylinder Down 1.Yes 2.No: <input style="width: 50px;" type="text" value="1"/>	Z-Axis Safety Height(mm): <input style="width: 50px;" type="text" value="50.000"/>
Cylinder Down Delay(s): <input style="width: 50px;" type="text" value="0.000"/>	Z-Axis Up Height(mm): <input style="width: 50px;" type="text" value="50.000"/>
Group 01 Dot Para PG 3/4	Group 01 Dot Para PG 4/4
Third Send Speed(mm/s): <input style="width: 50px;" type="text" value="10"/>	Shake Tin 1.Enable 2.Disable: <input style="width: 50px;" type="text" value="2"/>
Third Send Length(mm): <input style="width: 50px;" type="text" value="0.000"/>	Shake Dir 1.F/B 2.L/R 3.U/D: <input style="width: 50px;" type="text" value="1"/>
Third Back Speed(mm/s): <input style="width: 50px;" type="text" value="0.000"/>	Shake Cnt: <input style="width: 50px;" type="text" value="0"/>
Third Back Length(mm): <input style="width: 50px;" type="text" value="0.000"/>	Shake Length(mm): <input style="width: 50px;" type="text" value="10.000"/>
Third Heat Time(s): <input style="width: 50px;" type="text" value="0.000"/>	Shake Speed(mm/s): <input style="width: 50px;" type="text" value="10.000"/>
Cylinder Up 1.Yes 2.No: <input style="width: 50px;" type="text" value="1"/>	Send Tin When Shake 1.Yes 2.No: <input style="width: 50px;" type="text" value="1"/>
Cylinder Up Delay(s): <input style="width: 50px;" type="text" value="0.000"/>	Send Tin Speed(mm/s): <input style="width: 50px;" type="text" value="10.000"/>
Return 1.Back Original 2.Directly: <input style="width: 50px;" type="text" value="1"/>	

The parameters of spot solder are set up. There are "0-49" in total 50 groups. 0-49 can be set separately. As shown above: in order to improve the efficiency, the first delivery of tin is completed before moving to the solder joint, so the length of the first tin delivery cannot be too long to prevent the tin from falling down.

The tin feeding process of spot welding is as follows: after heating to the solder joint, it is heated for the first time, then sent to tin second times, second times heating, and then sent to tin third times, third times heating and tin stripping. In addition to the tin speed, each parameter can be 0.

5.15.2 Move speed para set (group function off)

Empty moving speed refers to the moving speed in the process from the completion of a section of the soldering process after moving to the next section of the soldering process, translation speed (XY axis) and up and down speed (Z axis), including rotation (A axis) speed are set independently, the size of this speed directly affects the efficiency of the process, but the setting should also refer to the actual performance of the machine and load weight and so on whether it can withstand.

5.16 Page 2 7 Drag para set/ Drag chang speed set

5.16.1 Drag para set (group function on)

Select the group first, and then go to the specific parameter setting page:

Drag Para Set

Group(0-49):

Group 01 Drag Para PG 1/4

First Send Speed(mm/s): 10
 First Send Length(mm): 0.000
 First Back Speed(mm/s): 50.000
 First Back Length(mm): 0.000
 First Heat Time(s): 0.000
 Cylinder Down 1.Yes 2.No: 1
 Cylinder Down Delay(s): 0.000

Group 01 Drag Para PG 2/4

Second Send Speed(mm/s): 10
 Second Send Length(mm): 0.000
 Second Back Speed(mm/s): 50.000
 Second Back Length(mm): 0.000
 Second Heat Time(s): 0.000

Group 01 Drag Para PG 3/4

Drag Send Speed(mm/s): 10
 Drag Move Speed(mm/s): 10.000
 Drag Ahead Stop Tin Len(mm): 0.000
 Drag Finish Heat Time(s): 0.000
 Cylinder Up 1.Yes 2.No: 1
 Cylinder Up Delay(s): 0.000
 Z-Axis Safety Height(mm): 50.000
 Z-Axis Up Height(mm): 50.000

Group 01 Drag Para PG 4/4

Shake Tin 1.Enable 2.Disable: 2
 Shake Dir 1.F/B 2.L/R 3.U/D: 1
 Shake Cnt: 0
 Shake Length(mm): 10.000
 Shake Speed(mm/s): 10.000
 Send Tin When Shake 1.Yes 2.No: 1
 Return 1.Back Original 2.Directly: 1
 Shake Send Tin Speed(mm/s): 10.000

5.16.2 Drag chang speed set (group function off)

This is used to set the line speed of drag soldering and the speed of tin output. When the wire speed is set to 0, it means that the wire speed of drag welding remains unchanged; when the tin output speed is set to 0, it means that the tin feeder does not feed tin.

Speed&Tin Set When Drag

Drag Speed(mm/s):
 Send Tin Speed(mm/s):
 Drag Speed Set '0' As Shiled
 Set Speed Set '0' As No Tin

5.17 Page 2 8. Close para set

If the vertical height is set to 3, the plane distance is set to 4, and the approach speed is set to 100, the soldering iron tip will take a slant line (slant line length is 5mm) from 3mm above the solder joint and 4mm away from the solder joint on the plane at a speed of 100mm per second to contact the solder joint, and the angle of deviation will be automatically adjusted according to the different angles of the rotation axis. This function is to

prevent the soldering iron from coming directly down and hitting the component pins.

5.18 Page 2 9 Show run state set/ Get product position

5.18.1 Show run state set (group function on)

Can be selected off or on, used to display the workpiece inspection and other functions of the state switching process. Generally used for debugging, the user does not need to pay attention to normal use.

5.18.2 Get product position (group function off)



5.19 Page 3 1. Start angle set

The angle refers to the relationship between the position of the soldering iron tip relative to the solder joint, the solder joint 12 o'clock direction is 0 degrees, clockwise angle increment, the value determines the starting direction of the action of the soldering iron tip contact solder joint, very important.

5.20 Page 3 2 Get product position/ Safety height set

5.20.1 Get product position (group function on)

When using the workpiece inspection function, the position where the product is taken out after machining (the position to which the Y-axis moves). Front release and then take out: the Y-axis goes to the maximum travel after machining; front release and take out: the Y-axis returns to the origin after machining.

5.20.2 Safety height set (group function off)

Safety height refers to the process of moving from one solder joint to the next, the Z-axis finally lift the height; lift height refers to raise to lift height, then start to go interpolation, that is, lift to lift height but not yet to the safety height, then the XY axis began to move; cylinder according to the user's own machine structure, if there is a cylinder can be set accordingly, in order to process efficiency, safety height and lift height should not be set Too large, as long as to ensure that the iron head will not hit the workpiece can be.

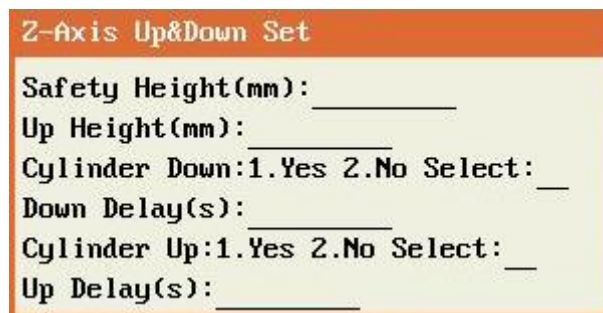

5.21 Page 3 3. Drag speed set

Drag soldering speed setting refers to the speed of the soldering iron tip movement during the process when the tip is drag soldering action; drag soldering output speed setting refers to the speed of tin output during drag soldering.

Drag Speed Set	
Drag Speed(mm/s):	_____
Send Tin Speed(mm/s):	_____

5.22 Page 3 4. Send&Back para set

Tin feeding and retreating parameters setting refers to the soldering process for the length, speed, heating time, and early stopping of the tin feeding length parameters of tin feeding and retreating. The parameters are set as follows: To improve efficiency, the first tin feed is completed before moving to the solder joint, so the length of the first tin feed cannot be too long to prevent the molten tin from falling off. The tin feeding process during processing is: to the solder joint after the first time heating, the second feeding tin, the second heating, the third feeding tin, the third heating, retreat tin. All the parameters except the tin feeding speed can be 0.

Send & Back Para PG 1/3	Send & Back Para PG 2/3
First Send Length(mm): _____	Second Send Length(mm): _____
First Send Speed(mm/s):_____	Second Send Speed(mm/s):_____
First Back Length(mm):_____	Second Back Length(mm):_____
First Back Speed(mm/s):_____	Second Back Speed(mm/s):_____
First Heat Time(s):_____	Second Heat Time(s):_____

Send & Back Para PG 2/3
Second Send Length(mm): _____
Second Send Speed(mm/s):_____
Second Back Length(mm):_____
Second Back Speed(mm/s):_____
Second Heat Time(s):_____

5.23 Page 3 5. Shale tin set

When encountering some large solder joints, the jitter function may be used. You can set the jitter in three directions: front and back, left and right, and up and down, as well as the number of jittering, the distance of jittering, the running speed of the soldering iron head when jittering, and the setting of whether tin comes out during jittering.

Shake Para Set	
Shake Tin	1.Enable 2.Disable: ___
Shake Dir	1.F/B 2.L/R 3.U/D: ___
Shake Cnt	: ___
Shake Length(mm)	: _____
Shake Speed(mm/s)	: _____
Send Tin When Shake	1.Yes 2.No: ___
Send Tin Speed(mm/s)	: _____

5.24 Page 3 6. Return set

After soldering a solder joint, the soldering iron tip leaves the path of the solder joint, the original path then follows the path of the soldering iron tip when contacting the solder joint to return in the original way, directly then directly lift the z-axis to the next solder joint.

Return Set	
Return	1.Back Original 2.Directly: <input type="text"/>

5.25 Page 3 7 Show run state set

When the group function is off, items 7 on the third page of menu 2 are for the status display during operation, This item is no different from when the group function is on.

Chapter 6 Menu 3

Menu 3 is mainly machine setting or menu operation, no programming point generated. Menu 3 contains:

Menu3	PG 1/3	Menu3	PG 2/3	Menu3	PG 3/3
1.Needle Move To		1.Key Voice On/Off		1.Run Select Area	
2.File Copy Option		2.Small Key Lock/Unlock		2.View Control Output	
3.Convert DXF File		3.File Name View			
4.File Lock/Unlock		4.Machine Information			
5.Machine Lock/Unlock		5.Program Edition			
6.File Lock Pass Set		6.Update APP			
7.Machine Lock Pass Set		7.View Input			
8.Input Name Edit		8.View Function Key			
9.Output Name Edit		9.Run From Cursor			

6.1 Page 1 1. Needle move to

After entering this menu, enter the coordinate value you want to move to and press "OK", the machine will move to the set coordinate position.

Move To Special Coor

X-Axis Coor(mm):

Y-Axis Coor(mm):

Z-Axis Coor(mm):

A-Axis Coor(deg):

6.2 Page 1 2. File copy option

This function can storage in U Disk or teach box and copy soldering files between each machine, when there are several machines process the same file, we can just program in one soldering machine and copy it to others. The teach box copying applies to the field using, and the U Disk copying can not only between soldering machines, but also storage in the computer as backup.

File copying operation contains:

1. From soldering machine to teach box

This operation copy the current soldering processing file to the teach box.

2. From soldering machine to U Disk

This operation copies the currently open soldering process file to the root directory of the USB drive, storing the file with the extension ".HXF". (Note: the U disk must be formatted to FAT32 format).

3. From teach box to soldering machine.

This operation copy the storage soldering file in the teach box to replace the current soldering processing file in the soldering machine.

4. From U Disk to soldering machine

Copy the soldering process file stored in the root directory of the USB drive to replace the soldering machine's currently open soldering process file. (Note: the U disk must be formatted to FAT32 format).

5. Copy between each soldering programs.

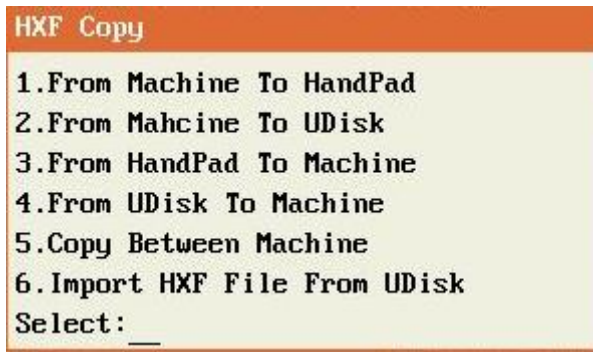

This operation copy soldering files with different File No. to replace, mainly used to make a soldering processing files backup. We can use the backup file when can't undo after an error program operation.



6.3 Page 1 3. Convert DXF file

Save the AutoCAD drawing file as an AutoCAD 2010 DXF format file, save it to the root directory of your USB drive, and then operate this menu to convert the drawing file into a machining file.

6.4 Page 1 4. File lock/unlock

When the file unlock, icon display  in the status bar, meanwhile the parameters of current file and machine all can be modified; when the file lock, icon display  in the status bar, meanwhile the current file can't be modified, but not the parameters of the machine.

6.5 Page 1 5. Machine lock/unlock

When in unlock states, the parameters of machine can be modified, whether the file is locked is up to the file lock/unlock setting; when in lock states, icon display  in the status bar, meanwhile all the parameters of soldering file and machine are locked.

6.6 Page 1 6. File lock pass set

This menu is used to set the password for the "Page 1 4.file locked".

6.7 Page 1 7. Machine lock pass set

This menu is used to set the password for the "Page 1 5.machine locked".

6.8 Page 1 8. Input name edit

The default name of programmable universal input port is “GPIO-I 01”—“GPIO-I 12”, to improve the readability of the program, each programmable universal input port can be named according to the function of the application, so that the programming is more convenient.

6.9 Page 1 9. Output name edit

The default name of programmable universal output port is “GPIO-O 01”—“GPIO-O 12”, to improve the readability of the program, each programmable universal output port can be named according to the function of the application, so that the programming is more convenient.

6.10 Page 2 1. Key voice on/off

This menu can set whether the key voice of teach box is on or off.

6.11 Page 2 2. Small key lock/unlock

Small keyboard means special keyboard for the check adjustment point, this menu usually used to prevent misuse with locking this keyboard and taking the teach box away.

6.12 Page 2 3. File name view

Because the soldering processing file is so many (150 files), it’s terrible to open and search file one by one, so we can use this function for tabbed browsing, find the number of file we wanted then open it, and press “delete” to delete the selected.

6.13 Page 2 4. Machine information

Display the device information, such as machine number, etc.

6.14 Page 2 5. Program edition

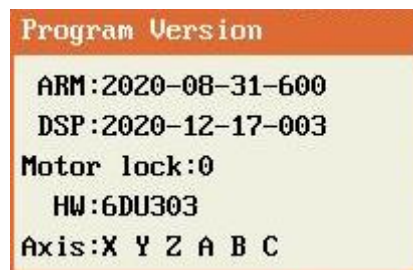

Display program version information, such as that shown in the figure above.

ARM: August 31, 2020 program code 600.

Motor lock: pulse output lock state.

HW: 6DU303 hardware version number.

Axis : X Y Z A B C axis information.

6.15 Page 2 6. Update app

Just put the application file into the root directory of the FAT32 format U disk, insert the U disk and enter the menu operation to update. If the U disk is inserted and can be read normally, the rightmost part of the status bar shows the U disk inserted icon as , if the U disk is not found after pressing OK, re-plug the U disk can be solved.

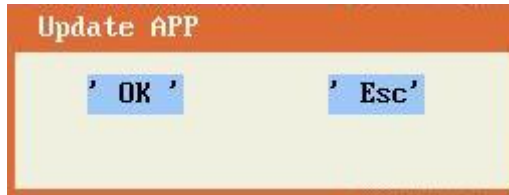

6.16 Page 2 7. View input

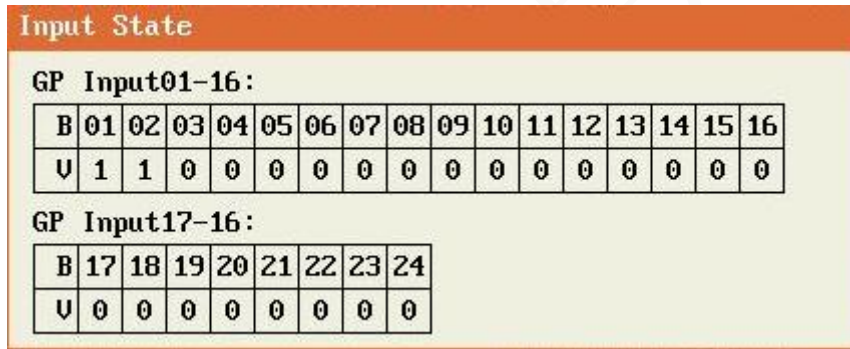

The screenshot shows a terminal window titled "Input State". It displays two tables of GPIO input states.

GP Input01-16:																
B	01	02	03	04	05	06	07	08	09	10	11	12	13	14	15	16
V	1	1	0	0	0	0	0	0	0	0	0	0	0	0	0	0

GP Input17-16:								
B	17	18	19	20	21	22	23	24
V	0	0	0	0	0	0	0	0

“GPIO-I 01”—“GPIO-I 06” are the origin signals of X, Y, Z, A and Y2 axes respectively, and the value is '1' when there is an input signal, and '0' when there is no input signal.

“GPIO-I 07”—“GPIO-I 08” is a programmable fast input port with the value of '1' when there is an input signal and '0' when there is no input signal.

The value of “GPIO-I 09”—“GPIO-I 24” is a programmable general input, and the value is '1' when there is an input signal, and '0' when there is no input signal.

6.17 Page 2 8. View function key

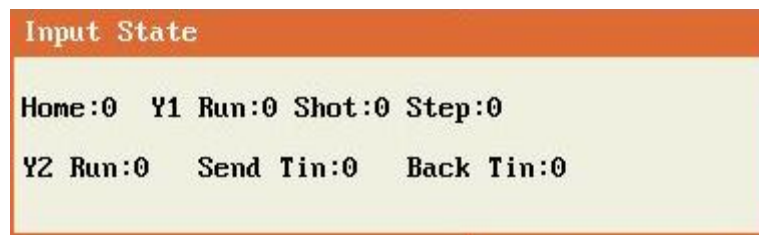

The screenshot shows a terminal window titled "Input State". It displays the status of various function keys.

```

Home:0  Y1 Run:0  Shot:0  Step:0
Y2 Run:0  Send Tin:0  Back Tin:0
    
```

Check the input status of the corresponding function button. If the button is not pressed, the status value is 0. If the button is pressed, the status value is 1.

6.18 Page 2 9. Run from cursor

Runs the machining program from the programming point where the cursor is currently located.

6.19 Page 3 1. Run select area

This function means we can choose the designated area in the programmed address to work independently.

Select Range

Start Addr: 0|

End Addr : 0

6.20 Page 3 2. View control output

View general output state, also control the output state of general output port. Set 1 means open the corresponding port, set 0 means close the corresponding port, as shown in the following figure.

Output State

GP Output :

B	01	02	03	04	05	06	07	08	09	10	11	12	13	14	15	16
V	p	0	0	0	0	0	0	0	0	0	0	0	0	0	0	1

Chapter 7 Menu 4

Press “Stop” + “Menu1” into Menu 4, Menu 4 is the menu for manufacturers to set parameters of machine, not recommend opening for users. Menu 4 contains:

Menu4	PG 1/5	Menu4	PG 2/5	Menu4	PG 3/5
1.X-Axis Para Set		1.Machine Name Edit		1.Program Change Mode	
2.Y-Axis Para Set		2.Company Name Edit		2.Y&A-Axis Num Set	
3.Z-Axis Para Set		3.Start/Stop Speed Set		3.System Para Copy	
4.A-Axis Para Set		4.Acc Set		4.Estop Mode	
5.Y2-Axis Para Set		5.Max Speed Set		5.Home Mode Of Power On	
6.Solder Axis Para Set		6.Go Home Speed Set		6.Machine Type Set	
7.Time Limited Pass Set		7.Manual Speed Set		7.Key Input Port Set	
8.Date/Time Set		8.Update IME		8.Output Port Set	
9.Time Limited Set		9.Update Power Screen		9.Driver Wire Mode	

Menu4	PG 4/5	Menu4	PG 5/5
1.A Negative Angle Set		1.Get Cylinder Port	
2.Input Port Set		2.Get Cylinder Delay	
3.Input Port Mode Set		3.Get Cylinder Sensor	
4.Output Port Set		4.Output Configure 1	
5.Run Mode In Double Y		5.System Language	
6.Protect Set		6.Init System Para	
7.Function Configure			
8.Clamp Port Set			
9.Sensor Check Port			

7.1 Page 1 1-6. X, Y, Z, A, Y2 axis para set

X-Axis Para	Y-Axis Para
Pluse Per Revolution:6400	Pluse Per Revolution:6400
Pitch(mm):52.000	Pitch(mm):52.000
Range(mm):200.000	Range(mm):200.000
Home Offset(mm):0.000	Home Offset(mm):0.000
Home:1.NC 2.NO 3.Shiled Select:2	Home:1.NC 2.NO 3.Shiled Select:2
Limit:1.NC 2.NO 3.Shiled Select:3	Limit:1.NC 2.NO 3.Shiled Select:3

Z-Axis Para	A-Axis Para
Pluse Per Revolution: <u>6400</u>	Pluse Per Revolution: <u>6400</u>
Pitch(mm): <u>52.000</u>	Pitch(deg): <u>52.000</u>
Range(mm): <u>100.000</u>	Range(deg): <u>200.000</u>
Home Offset(mm): <u>0.000</u>	Home Offset(deg): <u>0.000</u>
Home: 1.NC 2.NO 3.Shiled Select: <u>2</u>	Home: 1.NC 2.NO 3.Shiled Select: <u>2</u>
Limit: 1.NC 2.NO 3.Shiled Select: <u>3</u>	Limit: 1.NC 2.NO 3.Shiled Select: <u>3</u>

Y2-Axis Para	Tin Feeder Para
Pluse Per Revolution: <u>6400</u>	Pitch(mm): <u>52</u>
Pitch(mm): <u>52.000</u>	Pluse Per Revolution: <u>6400.000</u>
Range(mm): <u>300.000</u>	Manual Speed(mm/s): <u>20.000</u>
Home Offset(mm): <u>0.000</u>	
Home: 1.NC 2.NO 3.Shiled Select: <u>2</u>	
Limit: 1.NC 2.NO 3.Shiled Select: <u>3</u>	

For X, Y, Z, Y2 axes:

Pulse/r: means the number of pulses for the driver motor per revolution, or the fine fraction of driver motor.

Screw pitch: means the run distance for the driver motor per revolution, or the circumference of the belt pulley or the pitch of lead screw.

Length: The longest distance the axis can move.

Offset at origin: Home offset can be 0 or others, as well as offset the error value as coordinate 0 after capture the home position.

Close/Open: Close if capture sensor output low voltage when motor shaft don't trigger the origin, and the opposite is open.

No use: If you select no use, the axis does not use the origin or limited.

For the A-axis:

A axis is a rotary axis, so its travel and home position offset are described by angle, and the unit becomes degree. The pitch can be interpreted as the angle represented by one revolution of the motor shaft, for example, if the stroke is 360 and the pitch is 360, then the corresponding angle is the actual rotation of the shaft.

For tin-fed shafts:

Its parameters include: the circumference of the feeding wheel, the number of pulses per revolution of the feeding wheel (motor fine fraction), and the manual speed (speed in manual mode).

7.2 Page 1 7. Solder axis para set

Before set the use limit time, set the password first.

Set 8-Bit Pass

Input New: _____

Repeat New: _____

7.3 Page 1 8. Time limited pass set

As the use of time to limit the need have to refer to the clock machine, so if you set the time limit to modify the machine, you must enter a password that uses a time limit.

Date/Time Set

Date: 2021Y 05M 06D

Time: 20H 33M 42S

7.4 Page 1 9. Time limited set

Before using this function, you must first set the "Restricted Use Time Key", and then use the "Constant Control Key Generator" software to generate a 16-digit restricted use password.

Time Limit Set

No Use Time Limit

16Bit Pass For Use Limit

7.5 Page 2 1. Machine name edit

The name of device edited will display at "menu 3, page 2, 4. Machine's information".

Machine Name

Name: _____

7.6 Page 2 2. Company name edit

The name of company edited will display at "menu 3, page 2, 4. Machine's information".

Company Name

CN : _____

EN : _____

7.7 Page 2 3. Start/Stop speed Set

The motor has a process of acceleration and deceleration in motor control applications when running, to improve work efficiency, start/stop speed can set neither 0 nor too large, the greater the load, the smaller the start/stop speed, or it will cause the loss of step or mechanical noise, general recommendations in range of 0-20 mm/s.



7.8 Page 2 4. Acc set

The acceleration of each includes the following.

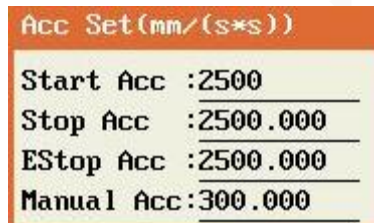

Acceleration can generally be set between 1000-10000, and have to corresponding modulation according to the mechanical bearing capacity and different load.

The manual move speed can set a little smaller in actual use, generally between 100-500, manual moving acceleration is set a little smaller to have an obvious start acceleration process in manual operation, it is easy to move a short distance when it is moving at a high speed, satisfied the speed and short distance requirements.

The control card support asymmetric acceleration and deceleration, start acceleration and stop acceleration can be set to different values, the actual application of the general will be set larger to stop the acceleration than the start acceleration. The acceleration of the size of the setting must be according to the motor drive capacity, load size, mechanical properties, etc. taking not lose step, shaking not big as the standard.

7.9 Page 2 5. Max speed set

Set the maximum speed allowed for each axis at the time of user programming. This prevents the user from setting a speed greater than the machine design requires and causing lost steps. Here, the XY axis maximum speed is the maximum speed allowed when air shifting in soldering application programming, the Z axis maximum speed is the maximum speed allowed when air shifting in soldering application programming, and the line segment maximum speed is the maximum speed allowed for drag welding in soldering application programming.



7.10 Page 2 6. Go home speed set

“move speed” is the speed that the motor shaft move from error direction to the direction of origin capture, this speed can be upper, generally set range as 50-150mm/s, “capture speed” is the speed that motor shaft move to trigger the origin signal, to improve the accuracy, this speed should not be too high, generally set range as 20-60mm/s.

Origin capture is record the position of motor shaft when it trigger the origin signal, in order to be in the same position every time, it must be triggered in the same direction every time, so we must move to the correct direction first then perform origin capture when the position of motor shaft is not at the direction of origin capture direction.

7.11 Page 2 7. Manual speed set

Manual movement speed is high, medium and low speed of three, press “speed” can cycle switch. Generally set high speed as 80mm/s, middle speed as 40mm/s, low speed as 1mm/s.



7.12 Page 2 8. Update ime

Pinyin IME use the GB2312 library, almost 7000 commonly used Chinese characters, usually the factor has been updated the Pinyin IME, so it's no need to perform this action.

7.13 Page 2 9. Update power screen

Make a 480 X 272 pixel, 24-bit color bitmap file of the desired boot screen in Photoshop, save the file in the root directory of the USB drive, insert it into the drive and perform the update operation. (Note: the flash drive must be formatted as FAT32).

7.14 Page 3 1. Program change mode

There are several ways to open the processing file program.



1. 232 communication: reserved.

2. LED+key: Use the LED small panel way to open the processing file, the physical picture of the key is shown as follows.

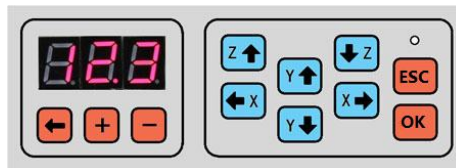

3. IO port selection: Use this function when using with PLC system, this function is combined with the "Port selection file parameter setting" function in menu 4. This function is used in conjunction with the "Port Selection File Parameter Setting" function in Menu 4.

7.15 Page 3 2. Y&A-axis num set

Set the number of Y-axis, according to the user's machine structure, single Y mode is used for single worktable and double Y mode is used for double worktable. After selecting double Y mode, you can set the start mode when double Y in item 5 on the fourth page of menu 4.

7.16 Page 3 3. System para copy

Copy the system parameters set in one machine to the teach box or USB flash drive and then copy them from the teach box or USB flash drive to other machines of the same model, without setting them one by one. When you save it to the USB flash drive, it will be saved to the root directory of the USB flash drive with the file extension ".CFG". (Note: the flash drive must be formatted to FAT32 format)

The copy includes each machine parameter that needs to be factory set as well as the default value parameters.

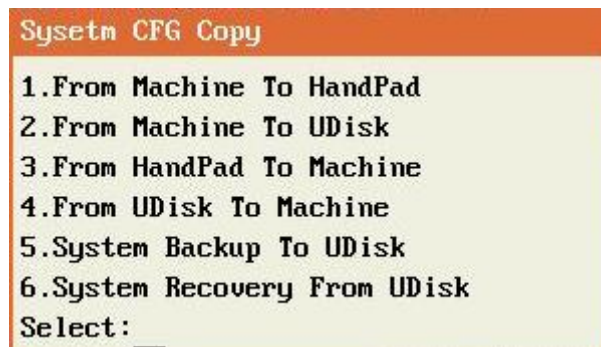

7.18 Page 3 4. Estop mode

When the "Emergency Stop" prompt appears, press the "Cancel" button to enter the emergency stop switch mode setting menu, so that if the emergency stop switch is damaged or if you want to modify the emergency stop switch mode, you can quickly make changes.

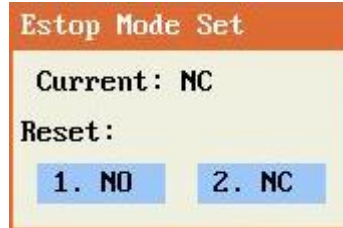

7.19 Page 3 5. Home mode of power on

1. Power-on prompt to return to the origin: prompt to return to the origin when the power is turned on, press the return button to execute the return action.

2. Return to the home position directly after power on: perform the return to the home position directly after power on.

3. no prompt, not back to the origin: no prompt after the power on, to press the home button to perform back to the home action.

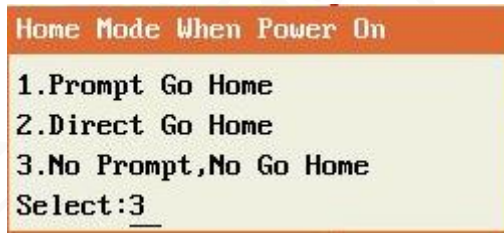

7.20 Page 3 6. Machine type set

Choose the correct mounting method according to the actual structure of the machine. This setting will directly affect the correctness of the return point and the direction of the machine movement.

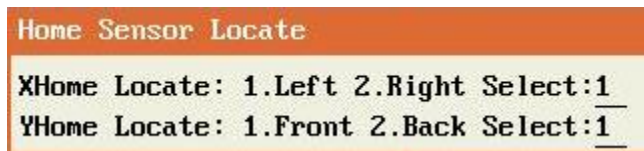

7.21 Page 3 7. Key input port set

Define the input port used for each function key. The same input port cannot be multiplexed, i.e. the same input port cannot be defined as different function ports at the same time. In dual Y mode, Y1 and Y2 start keys can be set separately.

Key Input Port Set	
Home Key:	0
Y1 Run/Pause:	0
Shot Key:	0
Step Key:	0
Y2 Run/Pause:	0
Estop Key:	0
Send Tin Key:	0
Back Tin Key:	0

7.22 Page 3 8. Output port set

The dedicated function output ports include run light, idle light, abnormal light, buzzer, and brake, and the dedicated function output ports cannot be multiplexed. In dual Y mode, Y1 and Y2 run lights can be set separately.

Output Port Set	
Y1 Running:	0
Idle Led:	0
Error Led:	0
Buzzer:	0
Break:	16
Y1 Running:	0

7.23 Page 3 9. Driver wire mode

When the driver wiring has been completed, but the motor axis movement direction is not correct because the direction pulse line is connected backwards, it can be adjusted directly in this menu without disassembling the machine and reconnecting it.

Connect Wire Mode Of Driver			
X-Axis Change Direction:	1.No	2.Yes	Select:1
Y-Axis Change Direction:	1.No	2.Yes	Select:1
Z-Axis Change Direction:	1.No	2.Yes	Select:1
A-Axis Change Direction:	1.No	2.Yes	Select:1
B-Axis Change Direction:	1.No	2.Yes	Select:1
C-Axis Change Direction:	1.No	2.Yes	Select:1

7.24 Page 4 1. A negative angle set

This item allows you to set whether the A-axis rotation axis allows negative angles during operation.

7.25 Page 4 2. Input port set

According to the actual situation, if the corresponding function is used, set the port number exactly, and pay

attention not to reuse it, or set it to 0 if it is not used.

Input Port Configure	
Block Tin Port	:0
No Tin Port	:0
Cylinder Up Sensor	:0
Cylinder Dn Sensor	:0

7.26 Page 4 3. Input port mode set

The signal type setting or masking of the input signal set in the previous item can be set according to the actual situation.

Input Port Type	
Block Tin Port:1.Shield 2.NC 3.NO Select	: 1
No Tin Input Port:1.Shield 2.NC 3.NO Select	: 1
Cylinder Up Sensor:1.Shield 2.NC 3.NO Select	: 1
Cylinder Dn Sensor:1.Shield 2.NC 3.NO Select	: 1

7.27 Page 4 4. Output port set

Set according to actual usage.

Output Port Configure	
Clean Iron Port	:0
UnDn Cylinder Port	:0
Output Port After Home	:0
Send Tin Port	:0
Y1 Work Finish Port	:0
Y2 Work Finish Port	:0

7.28 Page 4 5. Run mode in double Y

This parameter can be set when the number of Y-axis is set to double Y-axis; when the number of Y-axis is set to single Y-axis, this function is invalid.

Double Y Run Mode	
Current	: In-Order
Reset:	
	<input type="button" value="1. D-Start"/> <input type="button" value="2. In-Order"/>

Double start: After pressing the total running key, put the product, press Y1 to start, Y1 clamping cylinder works, clamping is completed and wait for the iron head to process when it is idle. Press Y2 to start, Y2 clamping cylinder work, clamping is completed and wait for the iron head idle when processing. Double start distinguishes

between Y1 and Y2 axis start.

General mode: After pressing the run button, it executes in sequence according to the actual programming point.

7.29 Page 4 6. Protect set

This function protects objects and people in the welding process. If the grating protect has induction, then it will stop running and alarming in the running or back to the origin state. In standby mode, there are grating protection, will prompt the grating sensor, but will not generate the alarm, at this time, the machine can not be returned to the origin and operation until the grating sensor disappears.

After the grating disappears delayed operation is, the grating sense into the pause state, the grating sense disappears, to run again, before the time required to delay the operation.

```
Protect Set
Protect Port:0
Type 1.NO 2.NC Select:1
Continue Delay When No Trigger(s):1.000
Resume Mode 1.Press Run 2.Delay Select:1
```

7.30 Page 4 7. Function configure

1. group function: the soldering parameters between different groups can be different. Almost every row of each group has different parameters of each group. Each group of programming instructions can share different sets of default solder parameters.

2. Go home and idle port: the next run can start directly from the idle port, it can improve the efficiency.

3. Whether to lift the z-axis when pausing: Whether to lift the z-axis when entering the paused state.

4. A-axis coordinates after reset: it means that after reset, the current position of A-axis is set to 0 degrees or set to 180 degrees.

```
Function Configure
Group Function 1.On 2.Off Select:2
Go Free When Home 1.Yes 2.No Select:1
Up Z When Pause 1.No 2.Yes Select:1
Iron Clean Num 1.One 2.Two Select:1
Clear Coor No Y 1.Yes 2.No Select:1
A-Axis Coor After Home 1.0 2.180 Select:1
```

7.31 Page 5 8. Clamp port set

Single Y mode:

```
Clamp Port Set
Clamp Port:0
Clamp Delay(s):0.000
```

Double Y mode:

```
Clamp Port Set
Y1 Clamp Port:0
Y1 Clamp Check:0
Type 1.NO 2.NC Select:1
Y1 Clamp Delay(s):0.000
Y2 Clamp Port:0
Y2 Clamp Check:0
Type 1.NO 2.NC Select:1
Y2 Clamp Delay(s):0.000
```

Clamping output signal port: the output port number of the solenoid valve driving the cylinder of the clamped workpiece, when set to the value of '0' then the function of the port is blocked.

Clamping input signal port: the input port number of the clamping sensor (usually pressure sensor or photoelectric sensor), when set to the value '0' then the function of the port is blocked.

Signal type: the signal type of the clamping sensor.

Output signal delay: After driving the clamping workpiece cylinder solenoid valve delayed for a period of time before executing the next action, can also be set to '0', the role of the delay is to wait for the cylinder action to complete, in order to work efficiency, should not be set too large.

7.32 Page 4 9. Sensor check port

Single Y mode:

```
Sensor Check Port
Product Sensor:0
Type 1.NO 2.NC Select:1
Sensor Product Delay(s):0.000
Take Product Delay(s):0.000
Sensor Mode 1.Auto 2.Manual Select:1
```

Double Y mode:

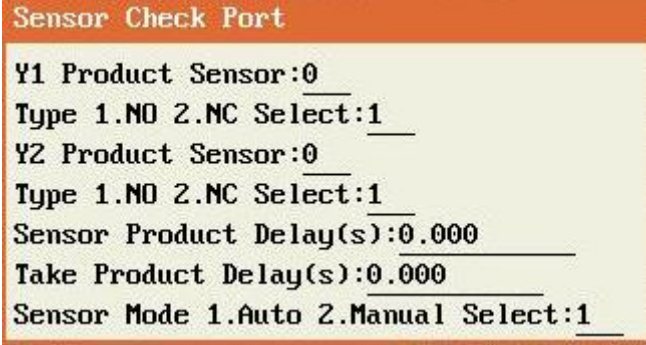

Workpiece detection signal port: the input port number of the workpiece detection sensor (generally photoelectric sensor), when set to the value of '0' then the function of the port is blocked.

Signal type: the signal type of the workpiece detection signal.

Delay after product detection: delay for a period of time after the product is detected before executing the next action, which can also be set to '0'.

Delay after taking away the product: Delay for a period of time after the processing is completed and the product is detected to be taken away before executing the next action, which can also be set to '0'.

7.33 Page 5 1. Get cylinder port

Single Y mode:

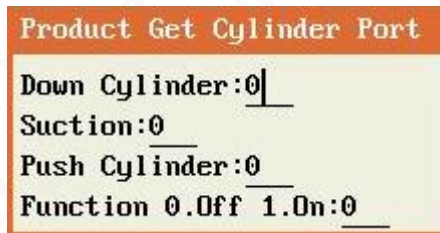

Double Y mode:

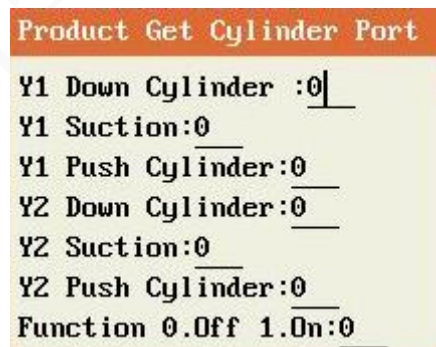

This function is to achieve automatic taking away of processed products, each cylinder port number is consistent with the actual wiring, note that the port cannot be multiplexed.

After the product is processed, the Y-axis goes to the stroke position, the vertical cylinder goes down, the suction cylinder opens, the vertical cylinder goes up, the horizontal cylinder pushes out, the suction cylinder releases, the product falls to the product line, and the horizontal cylinder retracts.

7.34 Page 5 2. Get cylinder delay

The single-Y model is shown below.

Product Get Cylinder Delay	
Down Cylinder Delay:	0.8
Push Cylinder Delay:	0.800
Suction Delay:	0.800

Vertical cylinder down delay: the output time of the vertical cylinder solenoid valve.

Horizontal cylinder push-out delay: the output time of the vertical cylinder solenoid valve.

Clamping cylinder release delay: The time required for the cylinder to clamp or release.

Double Y mode:

Product Get Cylinder Delay	
Y1 Down Cylinder Delay:	0.8
Y1 Push Cylinder Delay:	0.800
Y1 Suction Delay:	0.800
Y2 Down Cylinder Delay:	0.800
Y2 Push Cylinder Delay:	0.800
Y2 Suction Delay:	0.800

Y1 vertical cylinder down time: the output time of Y1 vertical cylinder solenoid valve.

Y1 transverse cylinder push-out time: the output time of Y1 transverse cylinder solenoid valve.

Y1 suction cylinder suction time: the output time of Y1 suction cylinder solenoid valve.

Y2 vertical cylinder down time: the output time of Y2 vertical cylinder solenoid valve.

Y2 transverse cylinder push-out time: the output time of Y2 transverse cylinder solenoid valve.

Y2 suction cylinder suction time: the output time of Y2 suction cylinder solenoid valve.

7.35 Page 5 3. Get cylinder sensor

The single-Y model is shown below.

Product Get Cylinder Sensor	
Down Cylinder Check:	0
Push Cylinder Check:	0
Suction Check:	0

Vertical cylinder down detection: vertical cylinder down detection in place.

Transverse cylinder out of position detection: transverse cylinder push out of position detection.

Suction cylinder detection: vacuum detection of suction cylinder.

The double-Y model is shown below:

```
Product Get Cylinder Sensor
Y1 Down Cylinder Check:0
Y1 Push Cylinder Check:0
Y2 Down Cylinder Check:0
Y2 Push Cylinder Check:0
Y1 Suction Check:0
Y2 Suction Check:0
```

Y1 vertical cylinder lower position detection: Y1 axis vertical cylinder upper position detection.

Y1 transverse cylinder out of position detection: Y1 transverse cylinder push out of position detection.

Y2 vertical cylinder lower position detection: Y2 axis vertical cylinder upper position detection.

Y2 transverse cylinder out of position detection: Y2 transverse cylinder push out of position detection.

Y1 suction cylinder detection: Y1 suction cylinder vacuum detection.

Y2 suction cylinder detection: Y2 suction cylinder vacuum detection.

7.36 Page 5 4. Output configure 1

In double Y mode, set Y1 and Y2 return buttons respectively.

```
Output Configure 1
Double Start Y1 Return Key:0
Double Start Y2 Return Key:0
```

7.37 Page 5 5. System language

You can set the system language, including Simplified Chinese, Traditional Chinese and English.

7.38 Page 5 6. Init system para

The parameters are initialized. After initialization, all parameters are restored to factory settings. Before initialization, please backup some important parameters such as the set port number and parameters of each motor, and then set them one by one after initialization.

Chapter 8 Default menu

Use "Stop" + "Menu 2" to enter the default parameter setting menu, and press the "Up, Down" button to go to the next line and the next page. The contents of this menu are not recommended for users, the default parameter setting menu includes the following contents:

Default Value	PG 1/2	Default Value	PG 2/2
1.X Move Speed:400		1.Close Speed :100	
2.Y Move Speed:400.000		2.AAxis Option:2.000	
3.Z Move Speed:100.000		3.Start Angle :270.000	
4.A Move Speed:30.000			
5.Default Temp:0.000			
6.Temp Error :0.000			
7.Heat Up Time:0.000			
8.Close Height:0.000			
9.Close Length:0.000			

The default parameters are mainly the processing parameters for soldering applications. If the above parameters are not set in the process programming, the parameters set in the default values are used.

Chapter 9 Menu show and hide

Use "Stop" + "Menu 3" to enter the "Menu Show and Hide" setting interface, the menu content is not recommended to open to users, the menu show and hide interface includes The following content:

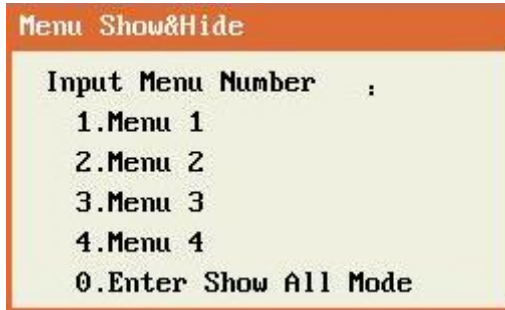

Select the menu you need to adjust: press the number corresponding to the menu to enter the interface as shown below, then press "OK" to select the function options to be shown or hidden, press the "Preview" button to select or clear all, press the Press the "Help" button to quickly reverse the selection. After finishing the setting, press "Cancel" to save and exit.



Enter the show all menu mode: After entering this mode, all the functions previously set to hide will be displayed, if you want to exit, press "0" to exit or power off and restart the system.